

EA3HMJ 23 cm feed

Analysis by SM6FHZ

Prerequisite

- Model dimension as per EME-newsletter February 2015
- Dimensions not published have been estimated i.e.
 - Probe diameter was set to 4mm diameter
 - Wave Guide wall thickness was set to 1mm
- Material was set to copper although stainless or galvanized steel is probably used in the real case. An simulation in stainless steel did not provide any different results. In the real word stainless steel would probably give additional losses compared to copper. No surface roughness applied in simulations.
- Circular polarization was generated by feeding the two orthogonal ports in quadrature in the simulation

Solid model

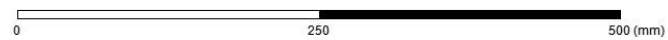
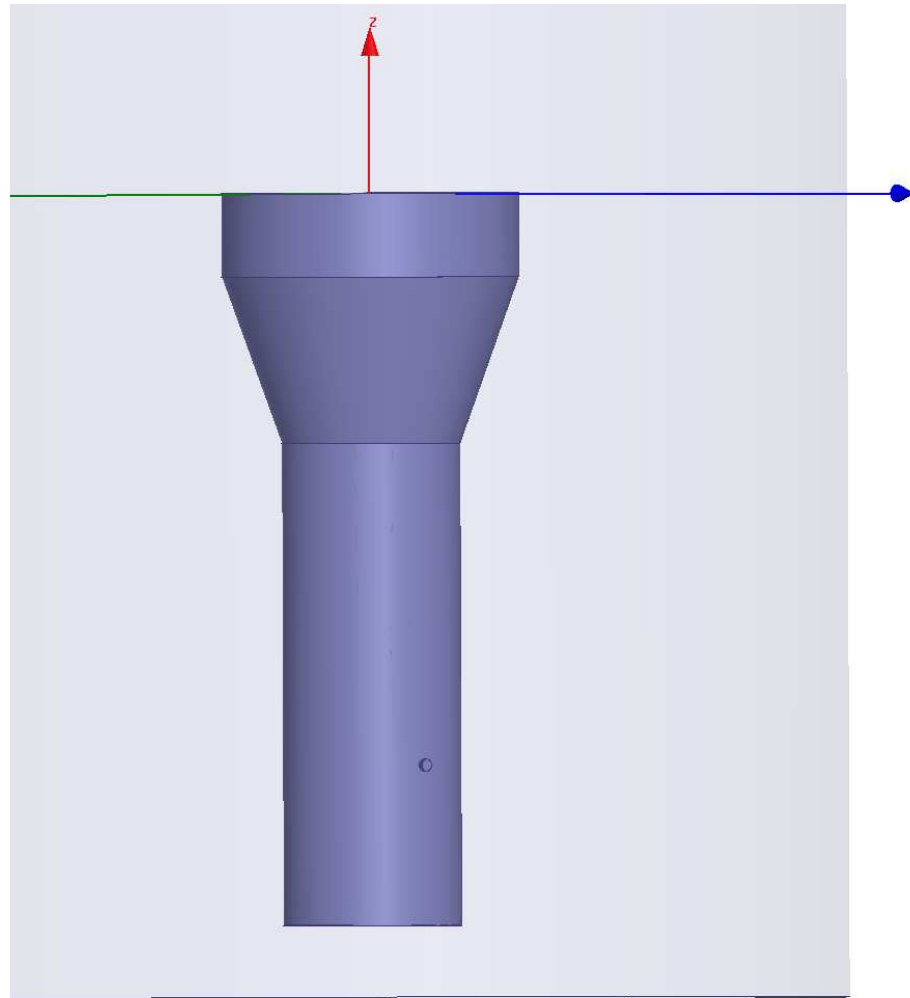

Transparent model

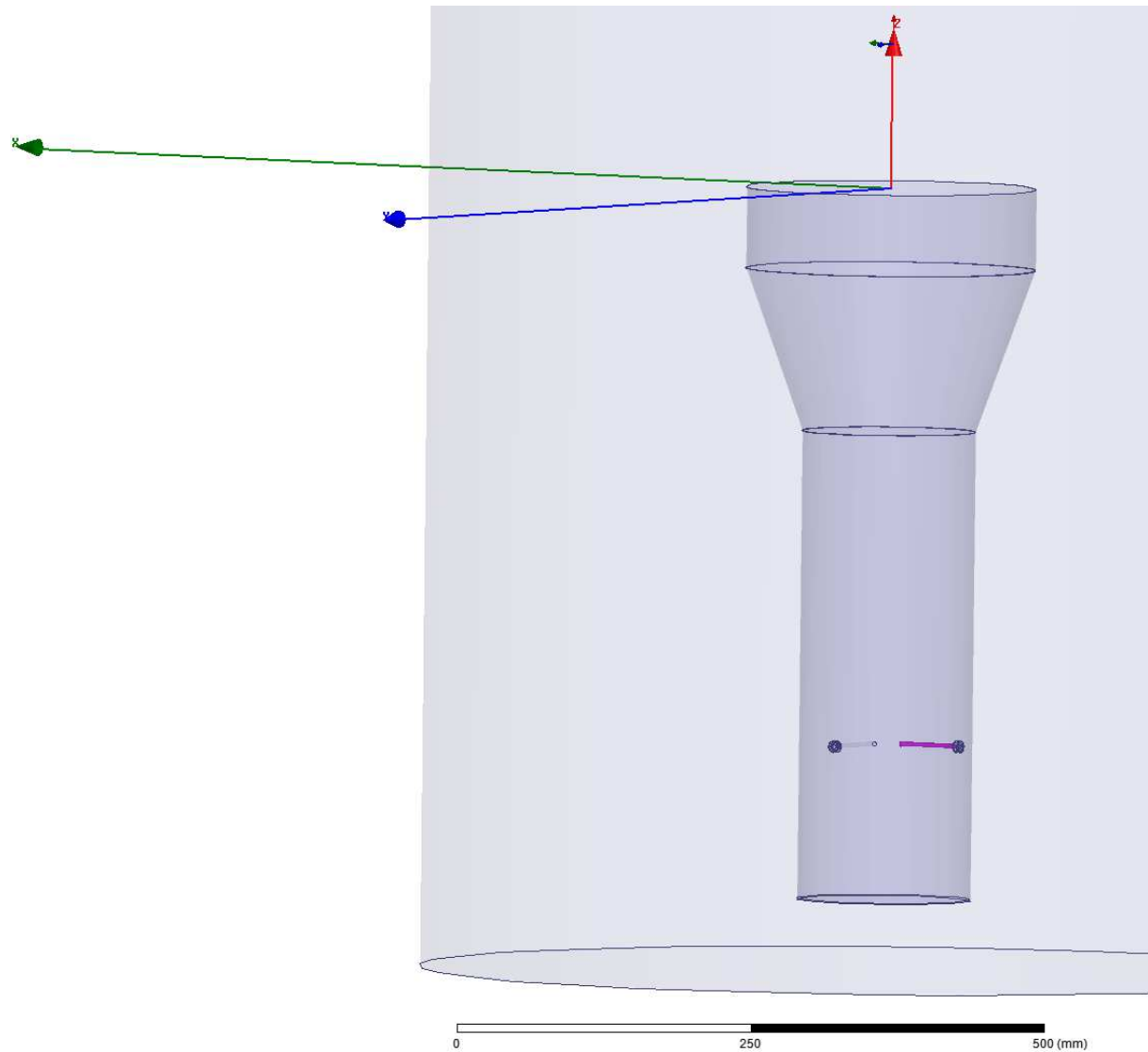

Comments on dimensions

- The position of the probes are not where you expect them to be to get best match.
- The length of the outer part of the feed is probably too short to get the wanted nulling of radiation in the backward direction (i.e. the two modes interact in that way)
- The angle of the transition from the narrow to the wide WG is crucial for good polarization properties. We have no control of this angle here

S-parameters

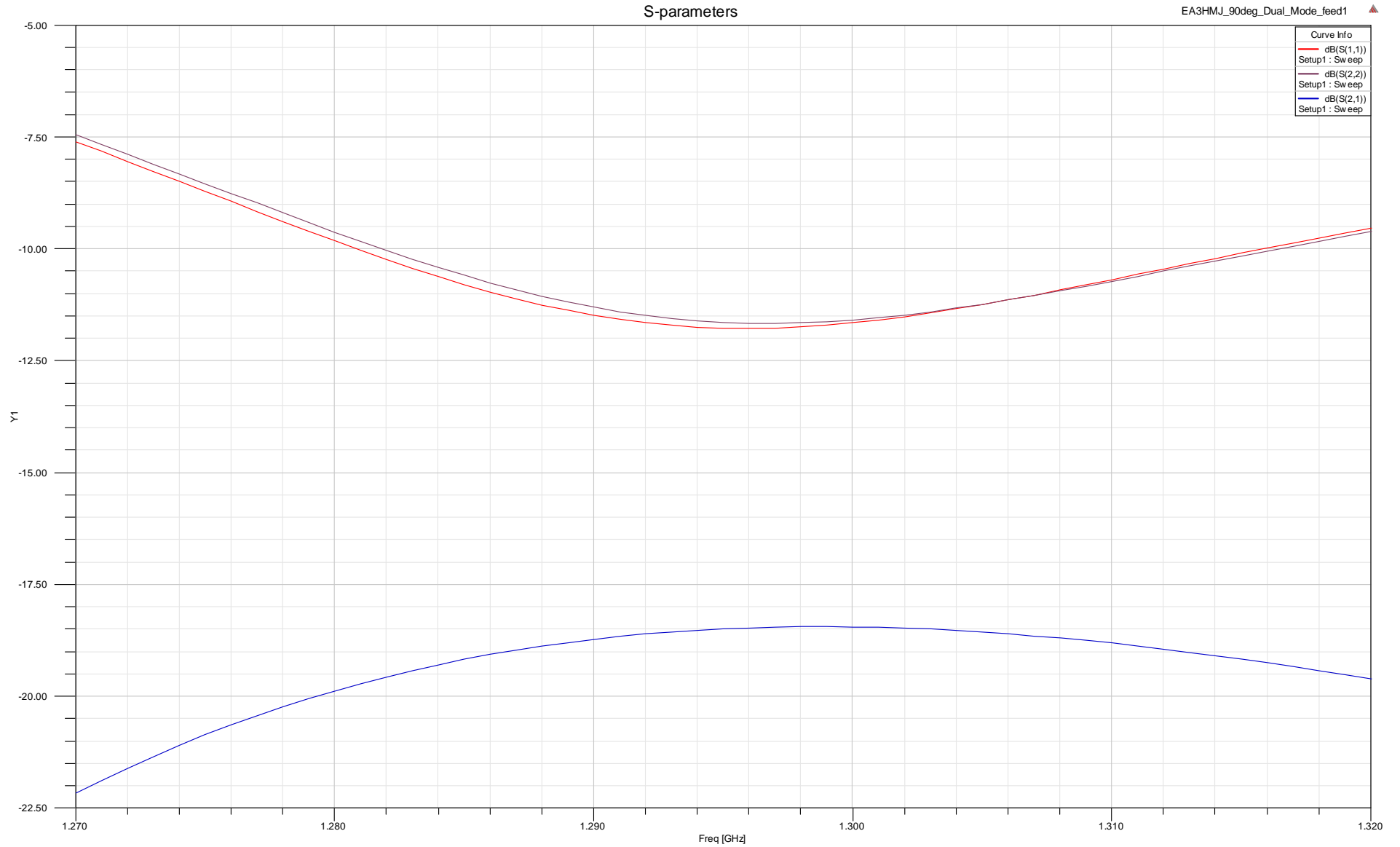

Co and Cross polar FF-patterns, Phi = 0 deg



Far Field Axial ratio



FF Cross Polar Ratio

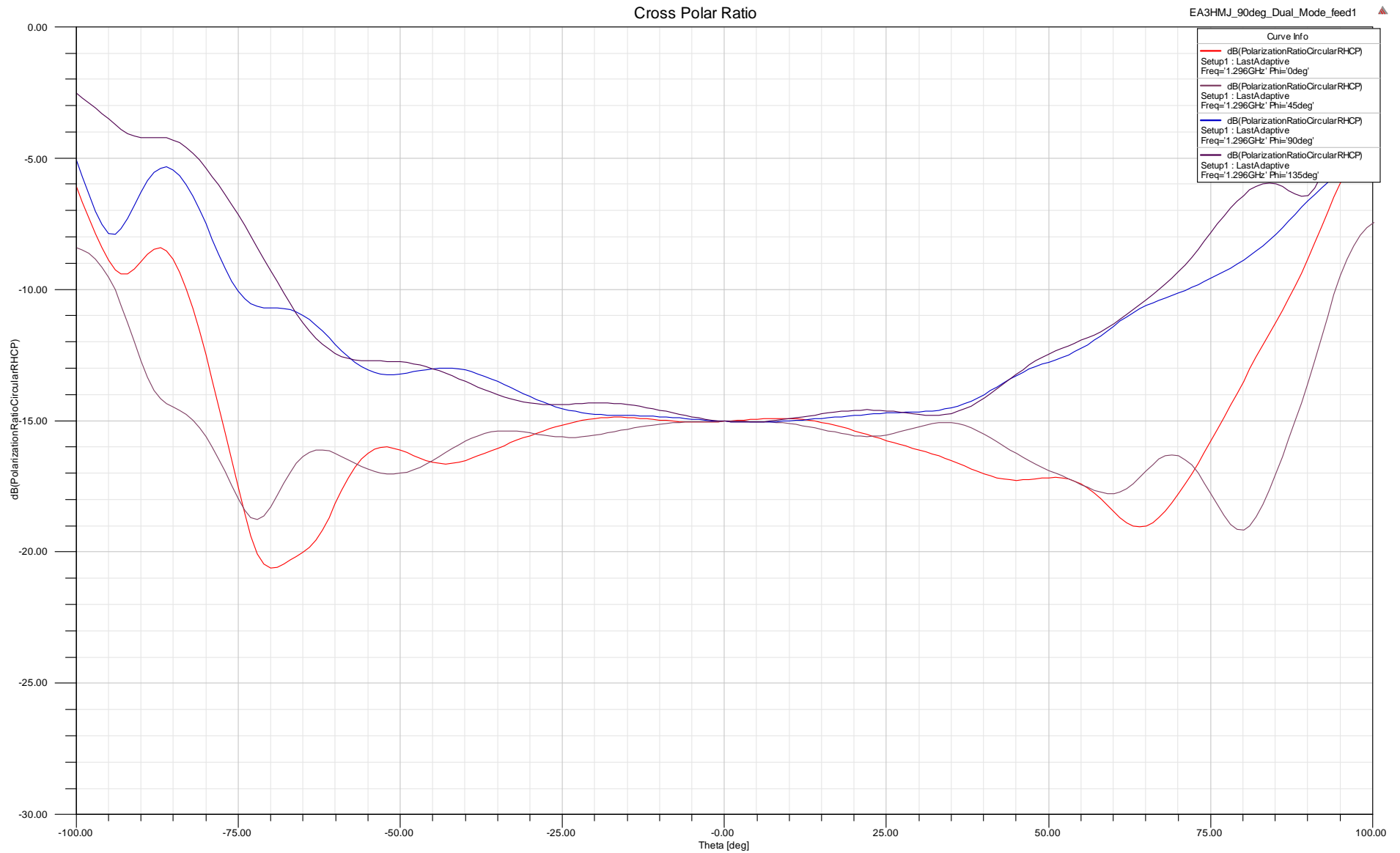

FF Phase error

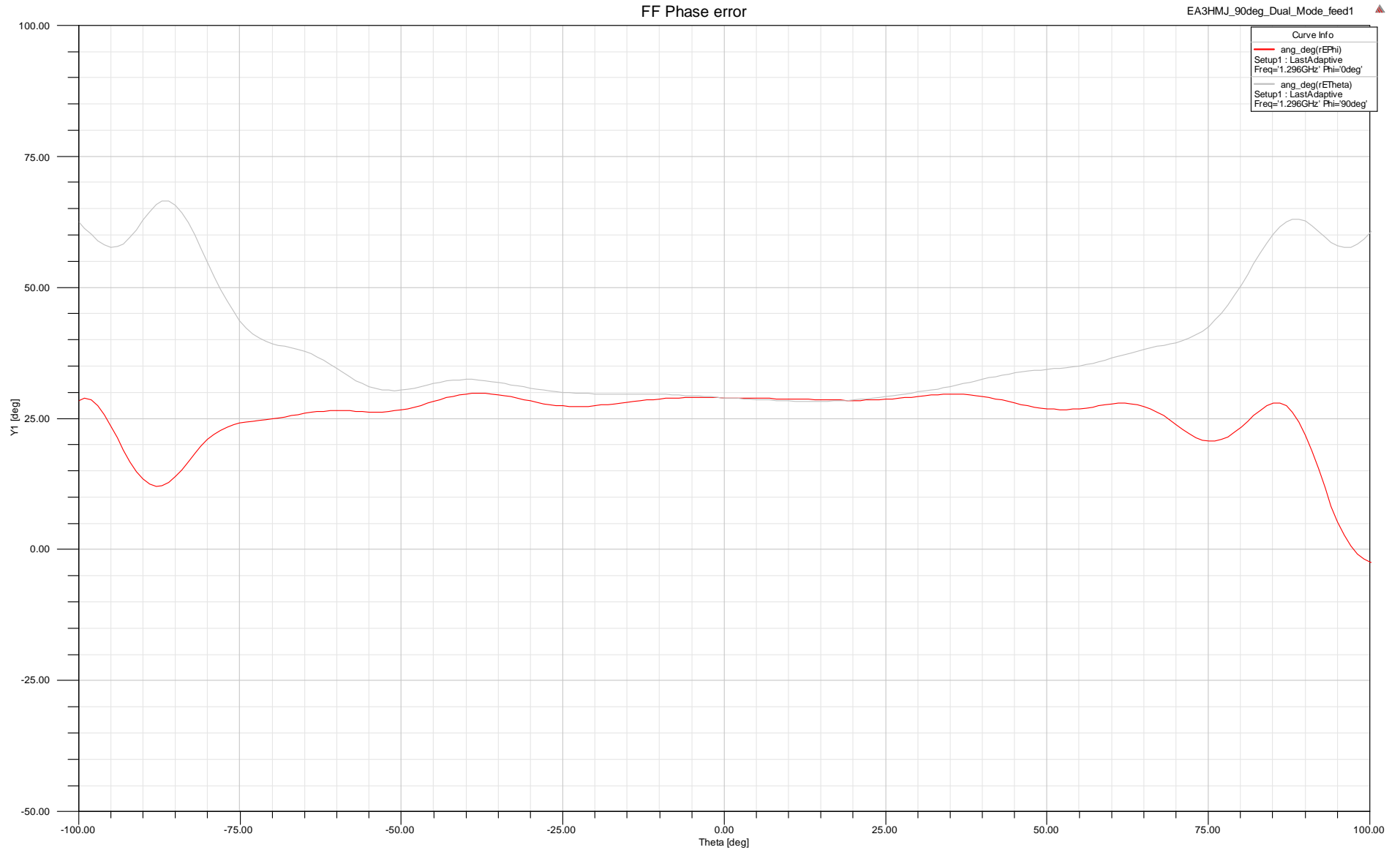

InDish performance

EA3HMJ Feed

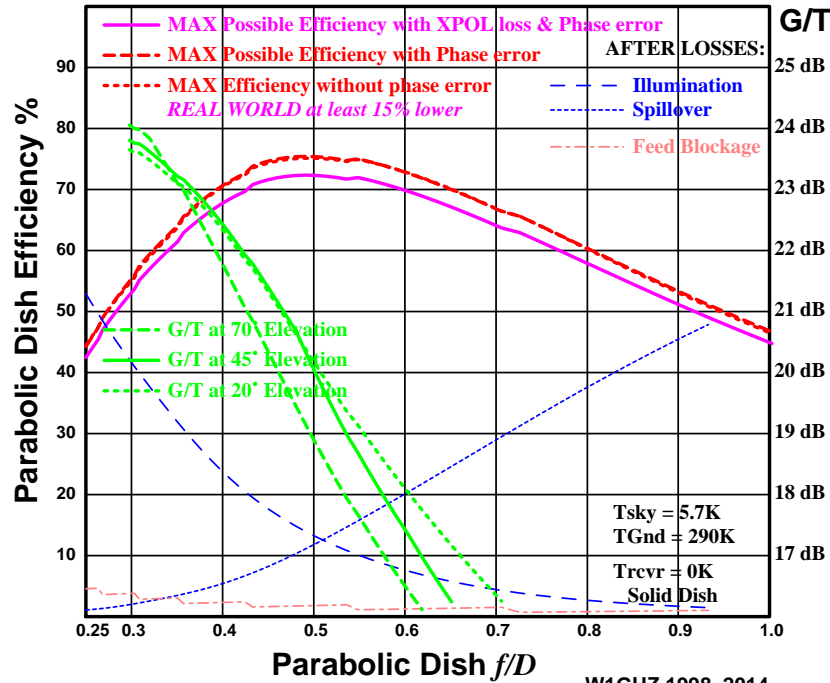
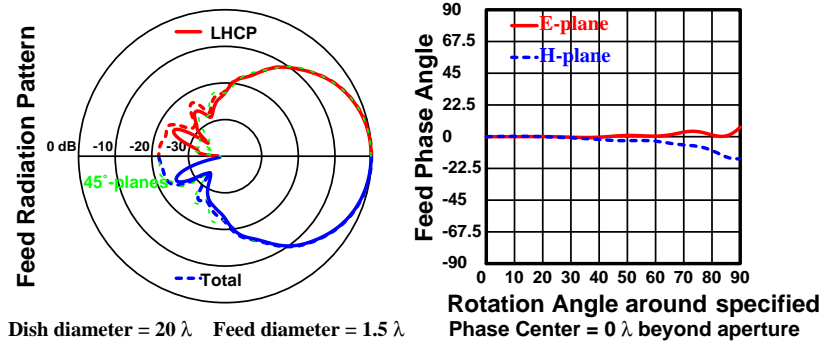

Conclusions

- Mediocre match and isolation
- Mediocre Axial Ratio
- More back radiation than from a W2IMU or N2UO Dual Mode Feed
- G/T at $f/D=0.4$ in an 20 wl dish is 1.5 dB inferior to the W2IMU or N2UO Dual Mode Feeds
- Simulation is probably optimistic with respect to losses in material and junctions. More noise will be generated due to the higher losses in real world